

MINI DVAS

SOLID CARBIDE TRISTAR DRILL SERIES
FAST, RELIABLE AND ACCURATE

B267E

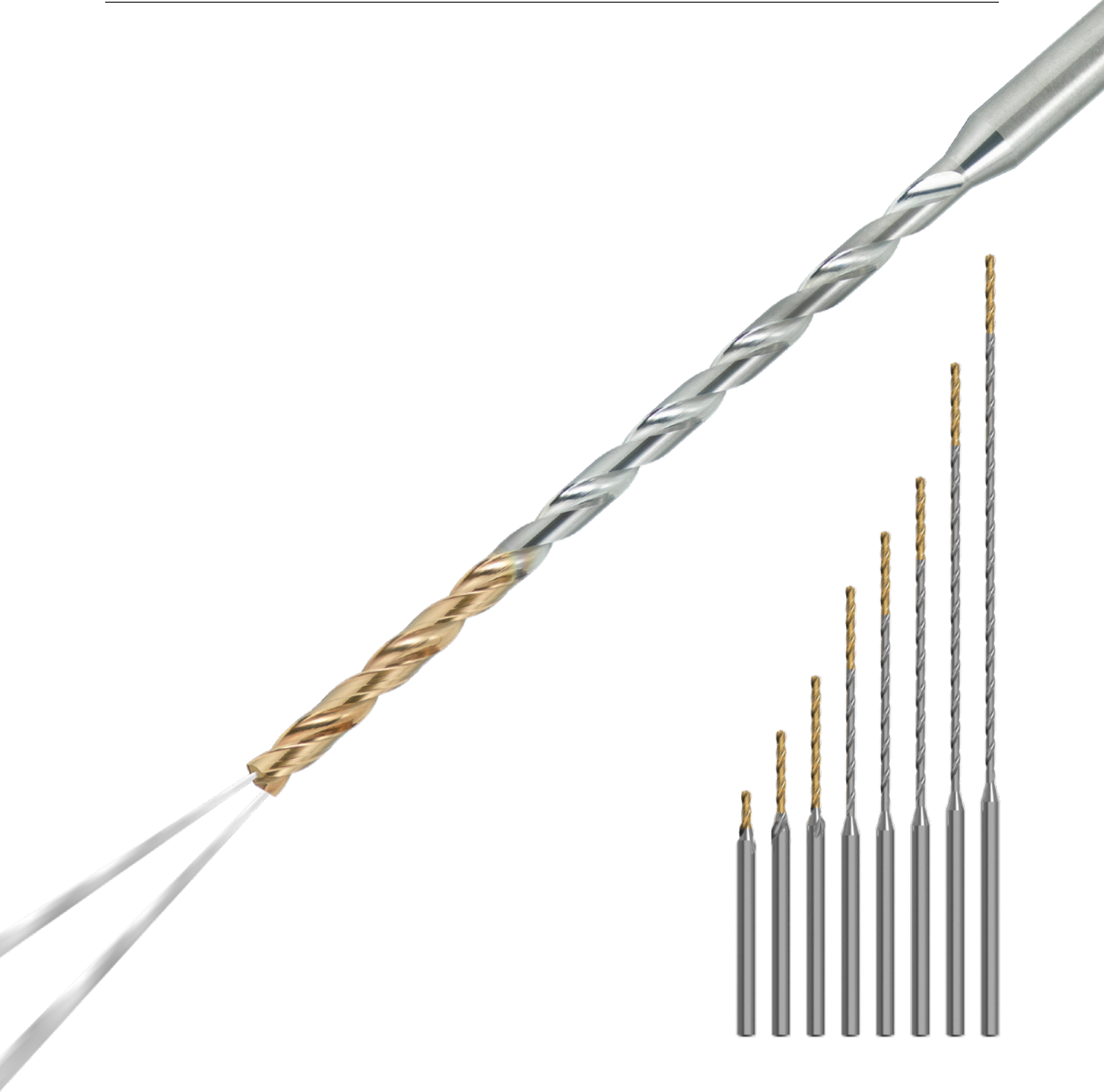

MINI DVAS

HIGH EFFICIENCY, LONG TOOL LIFE, HIGH PRECISION

TRISTAR, A NEW GENERATION DRILL SERIES PROVIDES 3 STRONG ADVANTAGES

TRISTAR: FAST

Conventional deep hole drilling is usually a slow process.

DVAS drills can perform at higher feeds and speeds meaning faster drilling cycles.



Cutting time 8 s/hole

TRISTAR: RELIABLE

Breakages, short tool life and lack of coolant can be common with standard tools.

DVAS – Tool life exceeds all normal expectations.

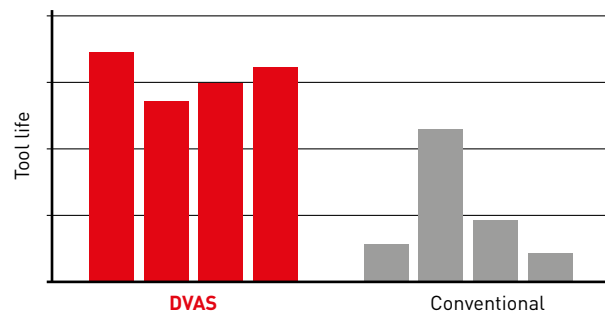

TRISTAR: ACCURATE

Conventionally drilled holes can wander considerably and have poor positioning.

Straighter holes and improved dimensional accuracy are enabled by using DVAS drills.

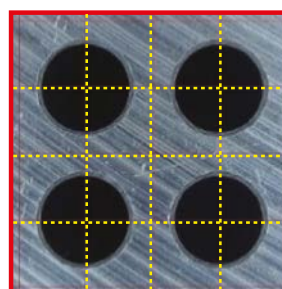
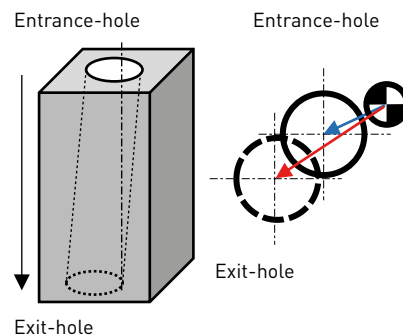

DVAS

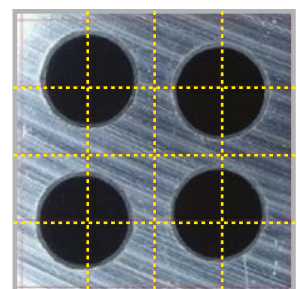

Conventional

MINI DVAS

FAST, RELIABLE AND ACCURATE NEW STANDARDS ENABLED BY FIVE TECHNOLOGIES

The first of the TRISTAR series is a small diameter drill with 5 technological features for fast, reliable and accurate drilling.

Ø 1.0 mm – Ø 2.9 mm L/D = 2 – 50

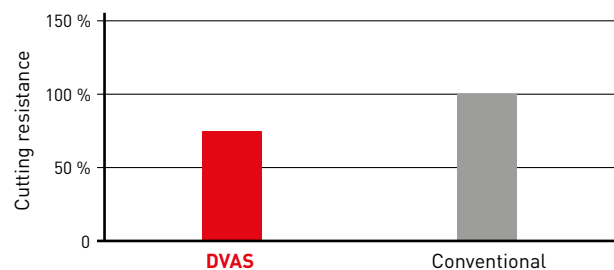
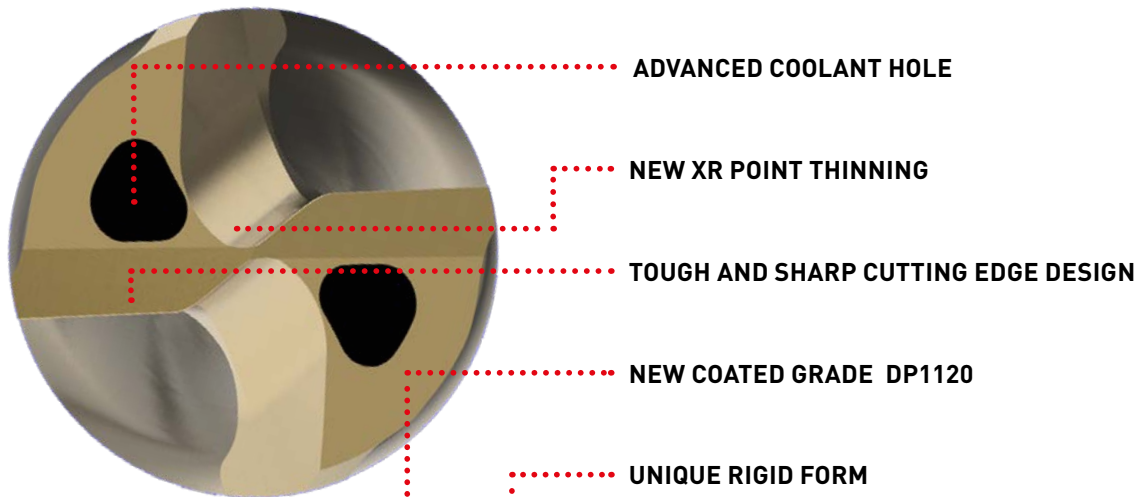

Material	42CrMo4
Tool	DC = Ø 1.0 mm, L/D = 20
Vc (m/min)	70
f (mm/rev)	0.04

MINI DVAS

COOLANT HOLES WITH TRI-COOLING TECHNOLOGY

TRI-Cooling is optimal for small-diameter drills and can achieve more than double the conventional coolant discharge volume. This can dramatically improve chip discharge and heat dissipation, contributing greatly to tool life stability.

Drill	DC = Ø2 mm, L/D = 20
Coolant	Water-soluble coolants

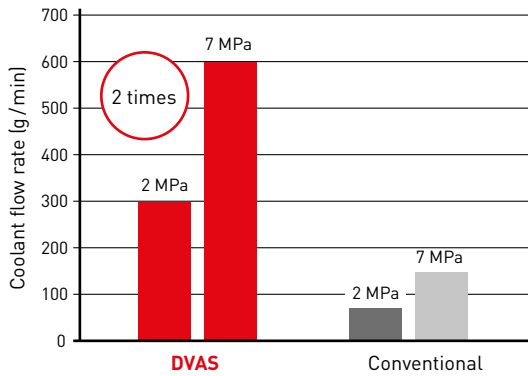

DVAS

Conventional

LARGE COOLANT HOLES IMPROVE COOLING EFFECT, REDUCE DAMAGE AND INCREASE TOOL LIFE

Increased coolant flow provides effective cooling even in difficult applications or when using an oil based cutting fluid.

COOLANT FLOW SPEED SIMULATION



DVAS

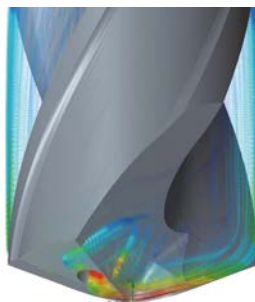

Conventional

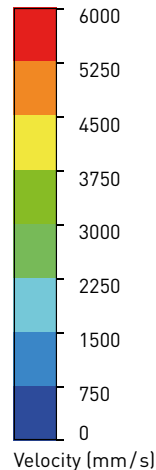

MINI DVAS

TOUGH, SHARP CUTTING EDGE DESIGN

The straight cutting edge and thinned point are connected by a smooth curved geometry that significantly improves fracture resistance. The geometry of the rake angle and land also improves tool wear and chip disposal.

Material	42CrMo4
Tool	DC = Ø2 mm, L/D = 20
Vc (m/min)	50
f (mm/rev)	0.06
Cutting mode	Wet cutting Water-soluble coolants, 2 MPa

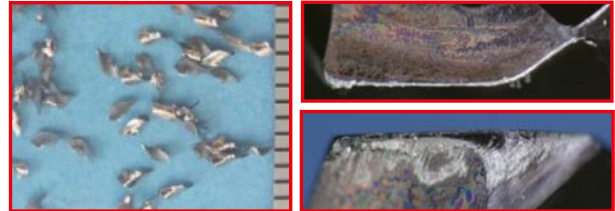

DVAS

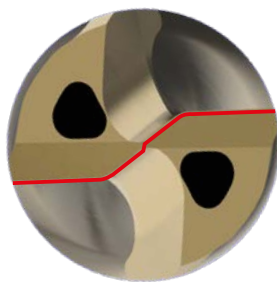

LARGE CRATER WEAR AND FRACTURE OF THE OUTER EDGE.

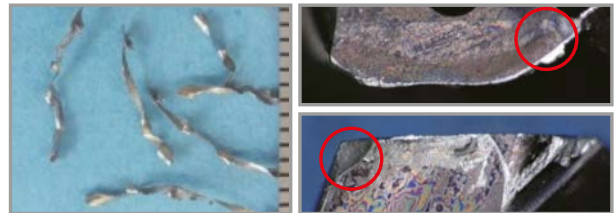

Conventional

NEW XR POINT THINNING, REDUCES CUTTING LOAD AND OPTIMISES CHIP FLOW

The new point thinning breaks chips into the optimum shape for a streamlined flow and achieves a much lower cutting resistance.

DVAS

The R shaped space created by the point thinning helps to form compact chips and aid flow.

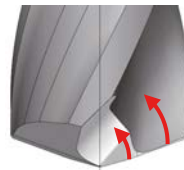
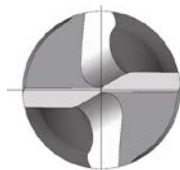

CONVENTIONAL DRILLS

Creates larger chips with a lower rate of flow that can cause chip clogging.

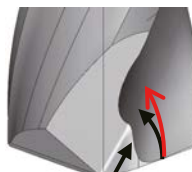
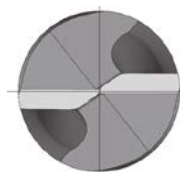

MINI DVAS

UNIQUE FLUTE FORM FOR GREATER RIGIDITY

The short drill is designed for high rigidity and good chip evacuation by minimizing the neck length. A chip discharge area is provided over the taper part, thus increasing tool rigidity by 20 % more than conventional models and in addition the extra strength improves hole position accuracy.

Applies to L/D = 2, 7, 12

DVAS

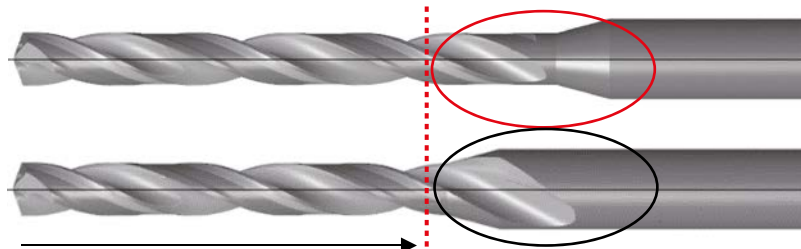

Conventional

Same maximum usable length.

COMPARISON OF TOOL RIGIDITY

Tool	DC = \varnothing 2 mm, L/D = 7
OAL (mm)	60
Constrained	Shank to tip range of 0-30 mm
Load	Distributed load of 140 N in Z axis direction

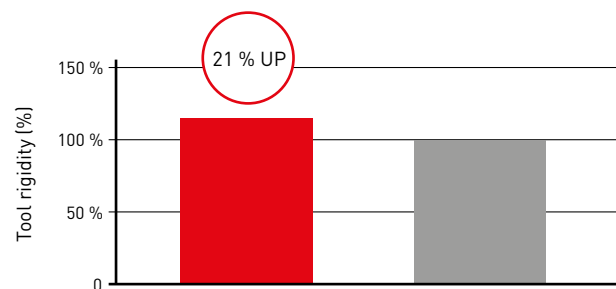

COMPARISON OF HOLE STRAIGHTNESS

Material	42CrMo4
Tool	DC = \varnothing 2 mm, L/D = 7
Vc (m/min)	70
f (mm/rev)	0.008
ap (mm)	10
Cutting mode	Wet cutting, water-soluble coolant, 5 MPa Hydro chuck
Number of holes	100

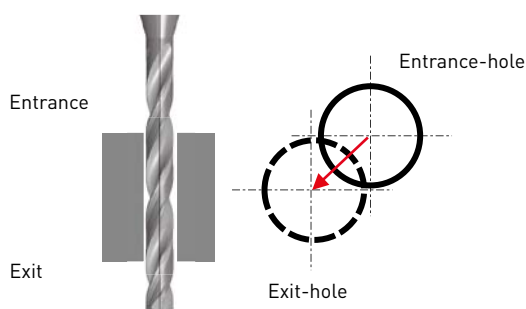
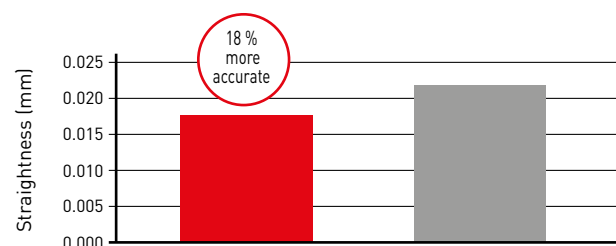

MINI DVAS

DEEP HOLE MACHINING EXAMPLE

For deep holes it is recommended to use a pilot drill to improve hole entry and reduce deviation at the exit point.

Material	42CrMo4
Tool	Pilot drill DC = Ø2 mm, L/D = 2
	Long drill DC = Ø2 mm, L/D = 20
Vc (m/min)	70
f (mm/rev)	0.07
Cutting mode	Wet cutting, water-soluble coolants, 5 MPa Hydro chuck
Number of holes	100

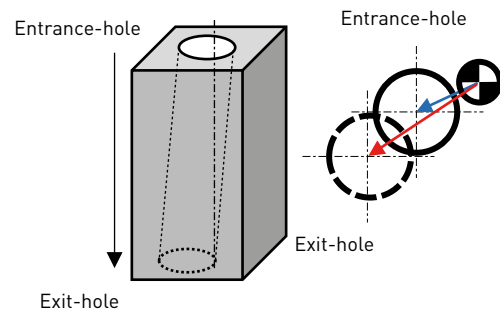
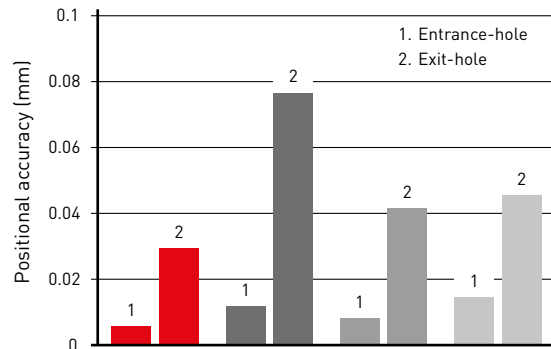

NEW COATED GRADE DP1120

DP1120 has a special multi-layer PVD coating and a micro-grain, cemented carbide substrate. The outstanding surface smoothness prevents chip clogging and reduces breakage. Additionally the excellent crater wear resistance maintains cutting edge sharpness to enable long tool life.

Tool	DC = Ø2 mm, L/D = 20
Vc (m/min)	50
f (mm/rev)	0.06
Cutting mode	Wet cutting, Water-soluble coolants, 2 MPa
Number of holes	500

ENLARGED VIEW OF THE FLUTE SURFACE

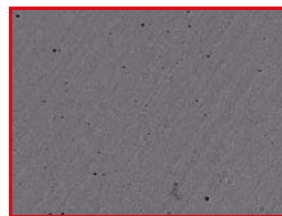

DVAS

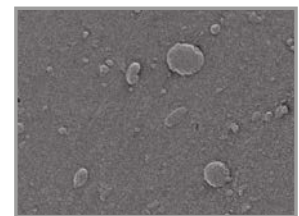

Conventional











DVAS

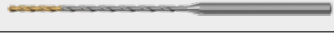

Conventional
Large crater wear

DRILLS SELECTION

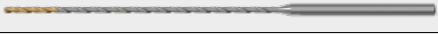
DVAS - SOLID CARBIDE TRISTAR DRILL SERIES

	Product code	DC	Size	Item	Hole depth	Material					Shape
						P	M	K	N	S	
Pilot drill	DVAS0100X02	Ø1.0 – Ø2.9	0.1	20	2	⊙	⊙	○	○	⊙	
	DVAS0100X07	Ø1.0 – Ø2.9	0.1	20	7	⊙	⊙	○	○	⊙	
	DVAS0100X12	Ø1.0 – Ø2.9	0.1	20	12	⊙	⊙	○	○	⊙	
	DVAS0100X20	Ø1.0 – Ø2.9	0.1	20	20	⊙	⊙	○	○	⊙	
Long drill	DVAS0100X25	Ø1.0 – Ø2.9	0.1	20	25	⊙	⊙	○	○	⊙	
	DVAS0100X30	Ø1.0 – Ø2.9	0.1	20	30	⊙	⊙	○	○	⊙	
	DVAS0100X40	Ø1.0 – Ø2.9	0.1	20	40	⊙	⊙	○	○	⊙	
	DVAS0100X50	Ø1.0 – Ø2.5	0.5	20	50	⊙	⊙	○	○	⊙	

IDENTIFICATION

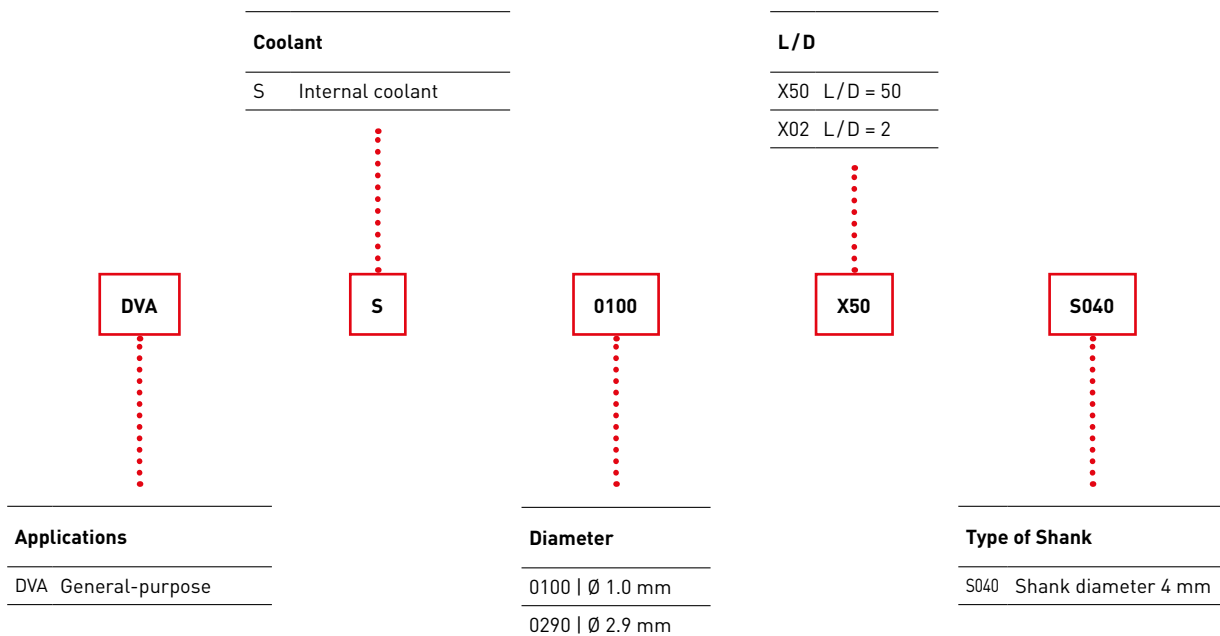

MINI DVAS



SOLID CARBIDE PILOT DRILLS - TRISTAR DRILLS

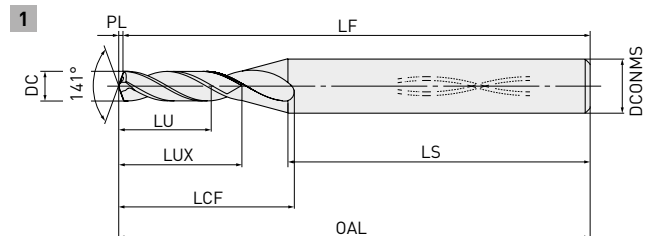

	DC < 3
	0.006 -0.004
	DCONMS = 4
	0 -0.008

Order number	DP1120	DC	DCONMS	L/D	LU	LUX	LCF	LS	OAL	LF	PL	Type
DVAS0100X02S040	●	1.0	4	2	2.2	3.2	8.6	41.2	50.0	49.8	0.2	1
DVAS0110X02S040	●	1.1	4	2	2.4	3.5	9.0	41.1	50.0	49.8	0.2	1
DVAS0120X02S040	●	1.2	4	2	2.6	3.9	9.4	41.0	50.0	49.8	0.2	1
DVAS0130X02S040	●	1.3	4	2	2.8	4.2	9.9	40.8	50.0	49.8	0.2	1
DVAS0140X02S040	●	1.4	4	2	3.0	4.5	10.3	40.7	50.0	49.8	0.2	1
DVAS0150X02S040	●	1.5	4	2	3.3	4.8	10.7	40.6	50.0	49.7	0.3	1
DVAS0160X02S040	●	1.6	4	2	3.5	5.1	11.1	40.4	50.0	49.7	0.3	1
DVAS0170X02S040	●	1.7	4	2	3.7	5.5	11.6	40.3	50.0	49.7	0.3	1
DVAS0180X02S040	●	1.8	4	2	3.9	5.8	12.0	40.2	50.0	49.7	0.3	1
DVAS0190X02S040	●	1.9	4	2	4.1	6.1	12.4	40.0	50.0	49.7	0.3	1
DVAS0200X02S040	●	2.0	4	2	4.4	6.4	12.9	39.9	50.0	49.6	0.4	1
DVAS0210X02S040	●	2.1	4	2	4.6	6.7	13.3	39.8	50.0	49.6	0.4	1
DVAS0220X02S040	●	2.2	4	2	4.8	7.0	13.7	39.7	50.0	49.6	0.4	1
DVAS0230X02S040	●	2.3	4	2	5.0	7.4	14.1	44.5	55.0	54.6	0.4	1
DVAS0240X02S040	●	2.4	4	2	5.2	7.7	14.6	44.4	55.0	54.6	0.4	1
DVAS0250X02S040	●	2.5	4	2	5.5	8.0	15.0	44.3	55.0	54.6	0.4	1
DVAS0260X02S040	●	2.6	4	2	5.7	8.3	15.4	44.1	55.0	54.5	0.5	1
DVAS0270X02S040	●	2.7	4	2	5.9	8.6	15.8	44.0	55.0	54.5	0.5	1
DVAS0280X02S040	●	2.8	4	2	6.1	8.9	16.3	43.9	55.0	54.5	0.5	1
DVAS0290X02S040	●	2.9	4	2	6.3	9.3	16.7	43.7	55.0	54.5	0.5	1

1/1



MINI DVAS



SOLID CARBIDE TRISTAR DRILL



DC < 3
0
-0.010



DCONMS = 4
0
-0.008

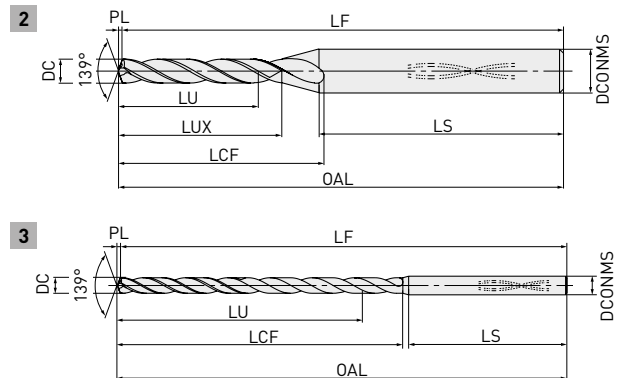

Order number	DP1120	DC	DCONMS	L/D	LU	LUX	LCF	LS	OAL	LF	PL	Type
DVAS0100X07S040	●	1.0	4	7	7.2	8.2	13.6	41.2	55.0	54.8	0.2	2
DVAS0100X12S040	●	1.0	4	12	12.2	13.2	18.6	39.2	58.0	57.8	0.2	2
DVAS0100X20S040	●	1.0	4	20	20.2	—	23.2	38.2	67.0	66.8	0.2	3
DVAS0100X25S040	●	1.0	4	25	25.2	—	28.2	39.2	73.0	72.8	0.2	3
DVAS0100X30S040	●	1.0	4	30	30.2	—	33.2	40.2	79.0	78.8	0.2	3
DVAS0100X40S040	●	1.0	4	40	40.2	—	43.2	41.2	90.0	89.8	0.2	3
DVAS0100X50S040	●	1.0	4	50	50.2	—	53.2	43.2	102.0	101.8	0.2	3
DVAS0110X07S040	●	1.1	4	7	7.9	9.1	14.5	40.6	55.0	54.8	0.2	2
DVAS0110X12S040	●	1.1	4	12	13.4	14.6	20.0	38.1	58.0	57.8	0.2	2
DVAS0110X20S040	●	1.1	4	20	22.2	—	25.5	36.1	67.0	66.8	0.2	3
DVAS0110X25S040	●	1.1	4	25	27.7	—	31.0	36.6	73.0	72.8	0.2	3
DVAS0110X30S040	●	1.1	4	30	33.2	—	36.5	37.1	79.0	78.8	0.2	3
DVAS0110X40S040	●	1.1	4	40	44.2	—	47.5	37.1	90.0	89.8	0.2	3
NEW DVAS0110X50S040	●	1.1	4	50	55.2	—	58.5	38.1	102.0	101.8	0.2	3
DVAS0120X07S040	●	1.2	4	7	8.6	9.9	15.4	40.0	55.0	54.8	0.2	2
DVAS0120X12S040	●	1.2	4	12	14.6	15.9	21.4	39.0	60.0	59.8	0.2	2
DVAS0120X20S040	●	1.2	4	20	24.2	—	27.8	38.0	71.0	70.8	0.2	3
DVAS0120X25S040	●	1.2	4	25	30.2	—	33.8	38.0	77.0	76.8	0.2	3
DVAS0120X30S040	●	1.2	4	30	36.2	—	39.8	39.0	84.0	83.8	0.2	3
DVAS0120X40S040	●	1.2	4	40	48.2	—	51.8	40.0	97.0	96.8	0.2	3
NEW DVAS0120X50S040	●	1.2	4	50	60.2	—	63.8	41.0	110.0	109.8	0.2	3
DVAS0130X07S040	●	1.3	4	7	9.3	10.7	16.4	39.3	55.0	54.8	0.2	2
DVAS0130X12S040	●	1.3	4	12	15.8	17.2	22.9	37.8	60.0	59.8	0.2	2
DVAS0130X20S040	●	1.3	4	20	26.2	—	30.1	35.8	71.0	70.8	0.2	3
DVAS0130X25S040	●	1.3	4	25	32.7	—	36.6	35.3	77.0	76.8	0.2	3
DVAS0130X30S040	●	1.3	4	30	39.2	—	43.1	35.8	84.0	83.8	0.2	3
DVAS0130X40S040	●	1.3	4	40	52.2	—	56.1	35.8	97.0	96.8	0.2	3
NEW DVAS0130X50S040	●	1.3	4	50	65.2	—	69.1	35.8	110.0	109.8	0.2	3

1/4

MINI DVAS – SOLID CARBIDE TRISTAR DRILL

Order number	DP1120	DC	DCONMS	L/D	LU	LUX	LCF	LS	OAL	LF	PL	Type
DVAS0140X07S040	●	1.4	4	7	10.1	11.5	17.3	38.7	55.0	54.7	0.3	2
DVAS0140X12S040	●	1.4	4	12	17.1	18.5	24.3	39.7	63.0	62.7	0.3	2
DVAS0140X20S040	●	1.4	4	20	28.3	—	32.5	37.7	75.0	74.7	0.3	3
DVAS0140X25S040	●	1.4	4	25	35.3	—	39.5	37.7	82.0	81.7	0.3	3
DVAS0140X30S040	●	1.4	4	30	42.3	—	46.5	38.7	90.0	89.7	0.3	3
DVAS0140X40S040	●	1.4	4	40	56.3	—	60.5	39.7	105.0	104.7	0.3	3
NEW DVAS0140X50S040	●	1.4	4	50	70.3	—	74.5	40.7	120.0	119.7	0.3	3
DVAS0150X07S040	●	1.5	4	7	10.8	12.3	18.2	38.1	55.0	54.7	0.3	2
DVAS0150X12S040	●	1.5	4	12	18.3	19.8	25.7	38.6	63.0	62.7	0.3	2
DVAS0150X20S040	●	1.5	4	20	30.3	—	34.8	35.6	75.0	74.7	0.3	3
DVAS0150X25S040	●	1.5	4	25	37.8	—	42.3	35.1	82.0	81.7	0.3	3
DVAS0150X30S040	●	1.5	4	30	45.3	—	49.8	35.6	90.0	89.7	0.3	3
DVAS0150X40S040	●	1.5	4	40	60.3	—	64.8	35.6	105.0	104.7	0.3	3
DVAS0150X50S040	●	1.5	4	50	75.3	—	79.8	35.6	120.0	119.7	0.3	3
DVAS0160X07S040	●	1.6	4	7	11.5	13.1	19.2	39.4	57.0	56.7	0.3	2
DVAS0160X12S040	●	1.6	4	12	19.5	21.1	27.2	40.4	66.0	65.7	0.3	2
DVAS0160X20S040	●	1.6	4	20	32.3	—	37.1	37.4	79.0	78.7	0.3	3
DVAS0160X25S040	●	1.6	4	25	40.3	—	45.1	38.4	88.0	87.7	0.3	3
DVAS0160X30S040	●	1.6	4	30	48.3	—	53.1	41.4	99.0	98.7	0.3	3
DVAS0160X40S040	●	1.6	4	40	64.3	—	69.1	39.4	113.0	112.7	0.3	3
NEW DVAS0160X50S040	●	1.6	4	50	80.3	—	85.1	40.4	130.0	129.7	0.3	3
DVAS0170X07S040	●	1.7	4	7	12.2	14.0	20.1	38.8	57.0	56.7	0.3	2
DVAS0170X12S040	●	1.7	4	12	20.7	22.5	28.6	39.3	66.0	65.7	0.3	2
DVAS0170X20S040	●	1.7	4	20	34.3	—	39.4	35.3	79.0	78.7	0.3	3
DVAS0170X25S040	●	1.7	4	25	42.8	—	47.9	35.8	88.0	87.7	0.3	3
DVAS0170X30S040	●	1.7	4	30	51.3	—	56.4	38.3	99.0	98.7	0.3	3
DVAS0170X40S040	●	1.7	4	40	68.3	—	73.4	35.3	113.0	112.7	0.3	3
NEW DVAS0170X50S040	●	1.7	4	50	85.3	—	90.4	35.3	130.0	129.7	0.3	3
DVAS0180X07S040	●	1.8	4	7	12.9	14.8	21.0	40.2	59.0	58.7	0.3	2
DVAS0180X12S040	●	1.8	4	12	21.9	23.8	30.0	41.2	69.0	68.7	0.3	2
DVAS0180X20S040	●	1.8	4	20	36.3	—	41.7	38.2	84.0	83.7	0.3	3
DVAS0180X25S040	●	1.8	4	25	45.3	—	50.7	39.2	94.0	93.7	0.3	3
DVAS0180X30S040	●	1.8	4	30	54.3	—	59.7	40.2	104.0	103.7	0.3	3
DVAS0180X40S040	●	1.8	4	40	72.3	—	77.7	41.2	123.0	122.7	0.3	3
NEW DVAS0180X50S040	●	1.8	4	50	90.3	—	95.7	43.2	143.0	142.7	0.3	3
DVAS0190X07S040	●	1.9	4	7	13.7	15.6	21.9	39.5	59.0	58.6	0.4	2
DVAS0190X12S040	●	1.9	4	12	23.2	25.1	31.4	40.0	69.0	68.6	0.4	2
DVAS0190X20S040	●	1.9	4	20	38.4	—	44.1	36.0	84.0	83.6	0.4	3
DVAS0190X25S040	●	1.9	4	25	47.9	—	53.6	36.5	94.0	93.6	0.4	3
DVAS0190X30S040	●	1.9	4	30	57.4	—	63.1	37.0	104.0	103.6	0.4	3
DVAS0190X40S040	●	1.9	4	40	76.4	—	82.1	37.0	123.0	122.6	0.4	3
NEW DVAS0190X50S040	●	1.9	4	50	95.4	—	101.1	38.0	143.0	142.6	0.4	3
DVAS0200X07S040	●	2.0	4	7	14.4	16.4	22.9	41.9	62.0	61.6	0.4	2
DVAS0200X12S040	●	2.0	4	12	24.4	26.4	32.9	42.9	73.0	72.6	0.4	2
DVAS0200X20S040	●	2.0	4	20	40.4	—	46.4	40.9	91.0	90.6	0.4	3
DVAS0200X25S040	●	2.0	4	25	50.4	—	56.4	41.9	102.0	101.6	0.4	3
DVAS0200X30S040	●	2.0	4	30	60.4	—	66.4	42.9	113.0	112.6	0.4	3
DVAS0200X40S040	●	2.0	4	40	80.4	—	86.4	45.9	136.0	135.6	0.4	3
DVAS0200X50S040	●	2.0	4	50	100.4	—	106.4	47.9	158.0	157.6	0.4	3

2/4



MINI DVAS – SOLID CARBIDE TRISTAR DRILL

Order number	DP1120	DC	DCONMS	L/D	LU	LUX	LCF	LS	OAL	LF	PL	Type
DVAS0210X07S040	●	2.1	4	7	15.1	17.2	23.8	41.3	62.0	61.6	0.4	2
DVAS0210X12S040	●	2.1	4	12	25.6	27.7	34.3	41.8	73.0	72.6	0.4	2
DVAS0210X20S040	●	2.1	4	20	42.4	—	48.7	38.8	91.0	90.6	0.4	3
DVAS0210X25S040	●	2.1	4	25	52.9	—	59.2	39.3	102.0	101.6	0.4	3
DVAS0210X30S040	●	2.1	4	30	63.4	—	69.7	39.8	113.0	112.6	0.4	3
DVAS0210X40S040	●	2.1	4	40	84.4	—	90.7	41.8	136.0	135.6	0.4	3
NEW DVAS0210X50S040	●	2.1	4	50	105.4	—	111.7	42.8	158.0	157.6	0.4	3
DVAS0220X07S040	●	2.2	4	7	15.8	18.1	24.7	40.6	62.0	61.6	0.4	2
DVAS0220X12S040	●	2.2	4	12	26.8	29.1	35.7	40.6	73.0	72.6	0.4	2
DVAS0220X20S040	●	2.2	4	20	44.4	—	51.0	36.6	91.0	90.6	0.4	3
DVAS0220X25S040	●	2.2	4	25	55.4	—	62.0	36.6	102.0	101.6	0.4	3
DVAS0220X30S040	●	2.2	4	30	66.4	—	73.0	36.6	113.0	112.6	0.4	3
DVAS0220X40S040	●	2.2	4	40	88.4	—	95.0	37.6	136.0	135.6	0.4	3
NEW DVAS0220X50S040	●	2.2	4	50	110.4	—	117.0	37.6	158.0	157.6	0.4	3
DVAS0230X07S040	●	2.3	4	7	16.5	18.9	25.7	43.0	65.0	64.6	0.4	2
DVAS0230X12S040	●	2.3	4	12	28.0	30.4	37.2	44.5	78.0	77.6	0.4	2
DVAS0230X20S040	●	2.3	4	20	46.4	—	53.3	41.5	98.0	97.6	0.4	3
DVAS0230X25S040	●	2.3	4	25	57.9	—	64.8	43.0	111.0	110.6	0.4	3
DVAS0230X30S040	●	2.3	4	30	69.4	—	76.3	44.5	124.0	123.6	0.4	3
DVAS0230X40S040	●	2.3	4	40	92.4	—	99.3	47.5	150.0	149.6	0.4	3
NEW DVAS0230X50S040	●	2.3	4	50	115.4	—	122.3	50.5	176.0	175.6	0.4	3
DVAS0240X07S040	●	2.4	4	7	17.2	19.7	26.6	42.4	65.0	64.6	0.4	2
DVAS0240X12S040	●	2.4	4	12	29.2	31.7	38.6	43.4	78.0	77.6	0.4	2
DVAS0240X20S040	●	2.4	4	20	48.4	—	55.6	39.4	98.0	97.6	0.4	3
DVAS0240X25S040	●	2.4	4	25	60.4	—	67.6	40.4	111.0	110.6	0.4	3
DVAS0240X30S040	●	2.4	4	30	72.4	—	79.6	41.4	124.0	123.6	0.4	3
DVAS0240X40S040	●	2.4	4	40	96.4	—	103.6	43.4	150.0	149.6	0.4	3
NEW DVAS0240X50S040	●	2.4	4	50	120.4	—	127.6	45.4	176.0	175.6	0.4	3
DVAS0250X07S040	●	2.5	4	7	18.0	20.5	27.5	41.7	65.0	64.5	0.5	2
DVAS0250X12S040	●	2.5	4	12	30.5	33.0	40.0	42.2	78.0	77.5	0.5	2
DVAS0250X20S040	●	2.5	4	20	50.5	—	58.0	37.2	98.0	97.5	0.5	3
DVAS0250X25S040	●	2.5	4	25	63.0	—	70.5	37.7	111.0	110.5	0.5	3
DVAS0250X30S040	●	2.5	4	30	75.5	—	83.0	38.2	124.0	123.5	0.5	3
DVAS0250X40S040	●	2.5	4	40	100.5	—	108.0	39.2	150.0	149.5	0.5	3
DVAS0250X50S040	●	2.5	4	50	125.5	—	133.0	40.2	176.0	175.5	0.5	3
DVAS0260X07S040	●	2.6	4	7	18.7	21.3	28.4	41.1	65.0	64.5	0.5	2
DVAS0260X12S040	●	2.6	4	12	31.7	34.3	41.4	41.1	78.0	77.5	0.5	2
DVAS0260X20S040	●	2.6	4	20	52.5	—	60.3	35.1	98.0	97.5	0.5	3
DVAS0260X25S040	●	2.6	4	25	65.5	—	73.3	35.1	111.0	110.5	0.5	3
DVAS0260X30S040	●	2.6	4	30	78.5	—	86.3	35.1	124.0	123.5	0.5	3
DVAS0260X40S040	●	2.6	4	40	104.5	—	112.3	35.1	150.0	149.5	0.5	3
NEW DVAS0260X50S040	●	2.6	4	50	130.5	—	138.3	35.1	176.0	175.5	0.5	3
DVAS0270X07S040	●	2.7	4	7	19.4	22.2	29.4	43.5	68.0	67.5	0.5	2
DVAS0270X12S040	●	2.7	4	12	32.9	35.7	42.9	45.0	83.0	82.5	0.5	2
DVAS0270X20S040	●	2.7	4	20	54.5	—	62.6	42.0	107.0	106.5	0.5	3
DVAS0270X25S040	●	2.7	4	25	68.0	—	76.1	43.5	122.0	121.5	0.5	3
DVAS0270X30S040	●	2.7	4	30	81.5	—	89.6	45.0	137.0	136.5	0.5	3
DVAS0270X40S040	●	2.7	4	40	108.5	—	116.6	48.0	167.0	166.5	0.5	3
NEW DVAS0270X50S040	●	2.7	4	50	135.5	—	143.6	51.0	197.0	196.5	0.5	3

3/4



MINI DVAS – SOLID CARBIDE TRISTAR DRILL

Order number	DP1120	DC	DCONMS	L/D	LU	LUX	LCF	LS	OAL	LF	PL	Type
DVAS0280X07S040	●	2.8	4	7	20.1	23.0	30.3	42.8	68.0	67.5	0.5	2
DVAS0280X12S040	●	2.8	4	12	34.1	37.0	44.3	43.8	83.0	82.5	0.5	2
DVAS0280X20S040	●	2.8	4	20	56.5	—	64.9	39.8	107.0	106.5	0.5	3
DVAS0280X25S040	●	2.8	4	25	70.5	—	78.9	40.8	122.0	121.5	0.5	3
DVAS0280X30S040	●	2.8	4	30	84.5	—	92.9	41.8	137.0	136.5	0.5	3
DVAS0280X40S040	●	2.8	4	40	112.5	—	120.9	43.8	167.0	166.5	0.5	3
NEW DVAS0280X50S040	●	2.8	4	50	140.5	—	148.9	45.8	197.0	196.5	0.5	3
DVAS0290X07S040	●	2.9	4	7	20.8	23.8	31.2	42.2	68.0	67.5	0.5	2
DVAS0290X12S040	●	2.9	4	12	35.3	38.3	45.7	42.7	83.0	82.5	0.5	2
DVAS0290X20S040	●	2.9	4	20	58.5	—	67.2	37.7	107.0	106.5	0.5	3
DVAS0290X25S040	●	2.9	4	25	73.0	—	81.7	38.2	122.0	121.5	0.5	3
DVAS0290X30S040	●	2.9	4	30	87.5	—	96.2	38.7	137.0	136.5	0.5	3
DVAS0290X40S040	●	2.9	4	40	116.5	—	125.2	39.7	167.0	166.5	0.5	3
NEW DVAS0290X50S040	●	2.9	4	50	145.5	—	154.2	40.7	197.0	196.5	0.5	3

4/4



MINI DVAS

RECOMMENDED CUTTING CONDITIONS

Material	DC	L/D	Vc	n	fr
P Mild steel Carbon steel, Alloy steel	1.0	2 – 30	65 (30 – 100)	20700	0.035 (0.020 – 0.050)
	1.0	40, 50	65 (30 – 100)	20700	0.030 (0.020 – 0.040)
	1.5	2 – 30	65 (30 – 100)	13800	0.053 (0.030 – 0.075)
	1.5	40, 50	65 (30 – 100)	13800	0.045 (0.030 – 0.060)
	2.0	2 – 30	70 (40 – 100)	11100	0.070 (0.040 – 0.100)
	2.0	40, 50	70 (40 – 100)	11100	0.060 (0.040 – 0.080)
	2.5	2 – 30	70 (40 – 100)	8900	0.088 (0.050 – 0.125)
	2.5	40, 50	70 (40 – 100)	8900	0.075 (0.050 – 0.100)
	2.9	2 – 30	70 (40 – 100)	7700	0.102 (0.058 – 0.145)
M Austenitic stainless steel, Ferritic stainless steel Ferritic and martensitic stainless steel Precipitation hardening stainless steel	1.0	2 – 30	60 (20 – 100)	19100	0.025 (0.010 – 0.040)
	1.0	40, 50	60 (20 – 100)	19100	0.020 (0.010 – 0.030)
	1.5	2 – 30	60 (20 – 100)	12700	0.038 (0.015 – 0.060)
	1.5	40, 50	60 (20 – 100)	12700	0.030 (0.015 – 0.045)
	2.0	2 – 30	60 (20 – 100)	9500	0.050 (0.020 – 0.080)
	2.0	40, 50	60 (20 – 100)	9500	0.040 (0.020 – 0.060)
	2.5	2 – 30	60 (20 – 100)	7600	0.063 (0.025 – 0.100)
	2.5	40, 50	60 (20 – 100)	7600	0.050 (0.025 – 0.075)
	2.9	2 – 30	60 (20 – 100)	6600	0.073 (0.029 – 0.116)
K Cast iron Ductile cast iron	1.0	2 – 30	70 (40 – 100)	22300	0.035 (0.020 – 0.050)
	1.0	40, 50	70 (40 – 100)	22300	0.030 (0.020 – 0.040)
	1.5	2 – 30	70 (40 – 100)	14900	0.053 (0.030 – 0.075)
	1.5	40, 50	70 (40 – 100)	14900	0.045 (0.030 – 0.060)
	2.0	2 – 30	70 (40 – 100)	11100	0.070 (0.040 – 0.100)
	2.0	40, 50	70 (40 – 100)	11100	0.060 (0.040 – 0.080)
	2.5	2 – 30	70 (40 – 100)	8900	0.088 (0.050 – 0.125)
	2.5	40, 50	70 (40 – 100)	8900	0.075 (0.050 – 0.100)
	2.9	2 – 30	70 (40 – 100)	7700	0.102 (0.058 – 0.145)
N Aluminium alloy	1.0	2 – 30	140 (100 – 180)	31800	0.040 (0.020 – 0.060)
	1.0	40, 50	140 (100 – 180)	31800	0.035 (0.020 – 0.050)
	1.5	2 – 30	140 (100 – 180)	21200	0.060 (0.030 – 0.090)
	1.5	40, 50	140 (100 – 180)	21200	0.053 (0.030 – 0.075)
	2.0	2 – 30	140 (100 – 180)	15900	0.080 (0.040 – 0.120)
	2.0	40, 50	140 (100 – 180)	15900	0.070 (0.040 – 0.100)
	2.5	2 – 30	140 (100 – 180)	12700	0.100 (0.050 – 0.150)
	2.5	40, 50	140 (100 – 180)	12700	0.088 (0.050 – 0.125)
	2.9	2 – 30	140 (100 – 180)	11000	0.116 (0.058 – 0.174)
2.9	40, 50	140 (100 – 180)	11000	0.102 (0.058 – 0.145)	

1/2

1. This recommended condition is only when using internal coolant.
2. Check the condition of chips and perform step machining if necessary. * Reference of step length: 0.2 to 1.0 DC
3. Adjust the cutting conditions according to machine tool and workpiece clamp rigidity and machining geometry, etc.
4. Machining depths exceeding flute length (LU) are not recommend.
5. Clamp the drill so that the drill runout is within 0.003 mm.
6. Do not clamp the flute part of the drill.

MINI DVAS

Material	DC	L/D	Vc	n	fr
Heat resistant alloy	1.0	2 - 30	30 (10 - 50)	9500	0.015 (0.010 - 0.020)
	1.0	40, 50	30 (10 - 50)	9500	0.015 (0.010 - 0.020)
	1.5	2 - 30	30 (10 - 50)	6400	0.023 (0.015 - 0.030)
	1.5	40, 50	30 (10 - 50)	6400	0.023 (0.015 - 0.030)
	2.0	2 - 30	30 (10 - 50)	4800	0.030 (0.020 - 0.040)
	2.0	40, 50	30 (10 - 50)	4800	0.030 (0.020 - 0.040)
	2.5	2 - 30	30 (10 - 50)	3800	0.038 (0.025 - 0.050)
	2.5	40, 50	30 (10 - 50)	3800	0.038 (0.025 - 0.050)
	2.9	2 - 30	30 (10 - 50)	3300	0.044 (0.029 - 0.058)
	2.9	40, 50	30 (10 - 50)	3300	0.044 (0.029 - 0.058)
S Titanium alloy	1.0	2 - 30	30 (20 - 40)	9500	0.020 (0.010 - 0.030)
	1.0	40, 50	30 (20 - 40)	9500	0.020 (0.010 - 0.030)
	1.5	2 - 30	30 (20 - 40)	6400	0.030 (0.015 - 0.045)
	1.5	40, 50	30 (20 - 40)	6400	0.030 (0.015 - 0.045)
	2.0	2 - 30	30 (20 - 40)	4800	0.040 (0.020 - 0.060)
	2.0	40, 50	30 (20 - 40)	4800	0.040 (0.020 - 0.060)
	2.5	2 - 30	30 (20 - 40)	3800	0.050 (0.025 - 0.075)
	2.5	40, 50	30 (20 - 40)	3800	0.050 (0.025 - 0.075)
	2.9	2 - 30	30 (20 - 40)	3300	0.058 (0.029 - 0.087)
	2.9	40, 50	30 (20 - 40)	3300	0.058 (0.029 - 0.087)
Cobalt chrome alloy	1.0	2 - 30	60 (30 - 90)	19100	0.020 (0.010 - 0.030)
	1.0	40, 50	60 (30 - 90)	19100	0.020 (0.010 - 0.030)
	1.5	2 - 30	60 (30 - 90)	12700	0.030 (0.015 - 0.045)
	1.5	40, 50	60 (30 - 90)	12700	0.030 (0.015 - 0.045)
	2.0	2 - 30	60 (30 - 90)	9500	0.040 (0.020 - 0.060)
	2.0	40, 50	60 (30 - 90)	9500	0.040 (0.020 - 0.060)
	2.5	2 - 30	60 (30 - 90)	7600	0.050 (0.025 - 0.075)
	2.5	40, 50	60 (30 - 90)	7600	0.050 (0.025 - 0.075)
	2.9	2 - 30	60 (30 - 90)	6600	0.058 (0.029 - 0.087)
	2.9	40, 50	60 (30 - 90)	6600	0.058 (0.029 - 0.087)



2/2

1. This recommended condition is only when using internal coolant.
2. Check the condition of chips and perform step machining if necessary. * Reference of step length: 0.2 to 1.0 DC
3. Adjust the cutting conditions according to machine tool and workpiece clamp rigidity and machining geometry, etc.
4. Machining depths exceeding flute length (LU) are not recommend.
5. Clamp the drill so that the drill runout is within 0.003 mm.
6. Do not clamp the flute part of the drill.

OPERATIONAL GUIDANCE

OPERATIONAL GUIDANCE FOR THE DVAS L/D = 2-40

FLAT FACE DRILLING DRILLING A BLIND HOLE

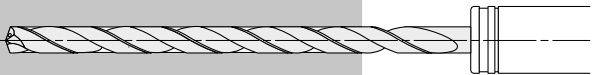
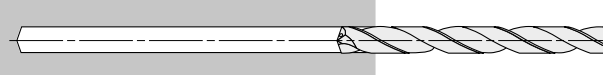



1. Drilling a pilot hole	2. Initial cutting with the long type drill
 <ol style="list-style-type: none"> 1. Use a drill with a larger (flatter) point angle than the super long type. Use the shortest flute possible. A DVAS drill with L/D = 2 can be machined up to L/D = 3 when drilling pilot holes. 2. Ensure a high precision hole is drilled for the guide. 3. Drill depth: Approx DC×3. (Adjust the pilot hole depth according to the length of the long type drill.) 	 <ol style="list-style-type: none"> 1. Penetrate the guide hole at low revolution. (Revolution 500-1000min⁻¹ feed rate 1000-2000 mm/min) 2. Stop the long type drill 1-3 mm short of the guide hole bottom.
3. Drill the deep hole	4. Drill retraction
 <ol style="list-style-type: none"> 1. Start cutting at the recommended speed and feed with a non-peck (continuous feed) cycle. 	 <ol style="list-style-type: none"> 1. After drilling, lower the cutting revolution about 0.5-1 mm short of the hole end. (Revolution of around 500-1000min⁻¹) 2. Retract the drill to the pilot hole depth starting point at a feed rate of 1000-2000 mm/min. 3. Finally, clear the hole at a cutting speed of 20-30m/min and feed rate of 0.2-0.3 mm/rev.

OPERATIONAL GUIDANCE

OPERATIONAL GUIDANCE FOR THE DVAS L/D = 2-40

INTERRUPTED DRILLING

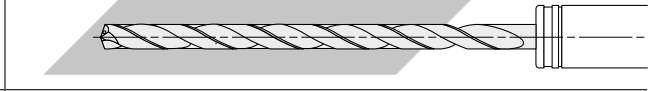
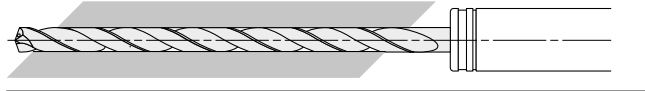



DRILLING AND BREAKING THROUGH ON IRREGULAR FACES OR ANGLES

<p>1. Spot facing</p>  <p>1. Machine a flat or the irregular face by using an end mill or slot drill capable of spot facing. Make the spot face diameter the same size as the required deep hole diameter.</p>	<p>2. Drilling a pilot hole</p>  <p>1. Use a drill with a larger (flatter) point angle than the super long type. Use the shortest flute possible. 2. Ensure a high precision hole is drilled for the guide. 3. Drill depth : Approx DC×2. (Adjust the pilot hole depth according to the length of the long type drill.)</p>
<p>3. Initial cutting with the long type drill</p>  <p>1. Penetrate the guide hole at a low revolution. (Revolution 500-1000min⁻¹, feed rate 1000-2000 mm/min) 2. Stop the long type drill 0.5-1 mm short of the guide hole bottom.</p>	<p>4. Drill the deep hole</p>  <p>1. Start cutting at the recommended speed and feed with a non-peck (continuous feed) cycle.</p>
<p>5. Breaking through</p>  <p>1. When breaking through, the cutting edge can be damaged. 2. Lower the feed rate when penetrating.</p>	<p>6. Drill retraction</p>  <p>1. Finally clear the hole at a feed rate of 0.2-0.3 mm/rev. (Revolution of around 500-1000min⁻¹) 2. Retract the drill to the pilot hole depth starting point at a feed rate of 1000-2000 mm/min.</p>

OPERATIONAL GUIDANCE

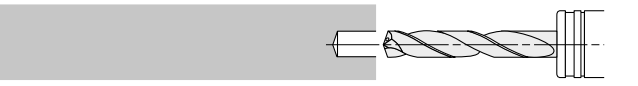
OPERATIONAL GUIDANCE FOR THE DVAS L/D = 50

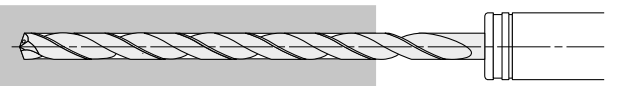
FLAT FACE DRILLING DRILLING A BLIND HOLE





1. Drilling a pilot hole	2. Initial cutting with the long type drill
 <ol style="list-style-type: none"> 1. Use a drill with a larger (flatter) point angle than the super long type. Use a DVAS drill with L/D = 7. 2. Ensure a high precision hole is drilled for the guide. 3. Drill depth : Approx DC×7. (Adjust the pilot hole depth according to the length of the long type drill.) 	 <ol style="list-style-type: none"> 1. Penetrate the guide hole at low revolution. (Revolution 500–1000min⁻¹ feed rate 1000–2000 mm/min) 2. Stop the long type drill 1–3 mm short of the guide hole bottom.
3. Drill the deep hole	4. Drill retraction
 <ol style="list-style-type: none"> 1. Start cutting at the recommended speed and feed with a non-peck (continuous feed) cycle. 	 <ol style="list-style-type: none"> 1. After drilling, lower the cutting revolution about 0.5–1 mm short of the hole end. (Revolution of around 500–1000min⁻¹) 2. Retract the drill to the pilot hole depth starting point at a feed rate of 1000–2000 mm/min. 3. Finally, clear the hole at a cutting speed of 20–30m/min and feed rate of 0.2–0.3 mm/rev.

OPERATIONAL GUIDANCE

OPERATIONAL GUIDANCE FOR THE DVAS L/D = 50

INTERRUPTED DRILLING

DRILLING AND BREAKING THROUGH ON IRREGULAR FACES OR ANGLES

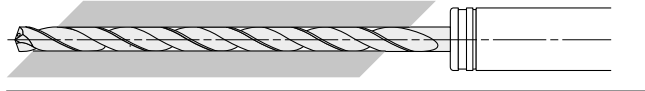
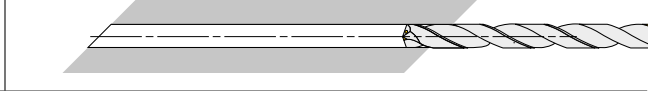
<p>1. Spot facing</p>  <p>1. Machine a flat or the irregular face by using an end mill or slot drill capable of spot facing. Make the spot face diameter the same size as the required deep hole diameter.</p>	<p>2. Drilling a pilot hole</p>  <p>1. Use a drill with a larger (flatter) point angle than the super long type. Use a DVAS drill with L/D = 7. 2. Ensure a high precision hole is drilled for the guide. 3. Drill depth: Approx DC×7. (Adjust the pilot hole depth according to the length of the long type drill.)</p>
<p>3. Initial cutting with the long type drill</p>  <p>1. Penetrate the guide hole at a low revolution. (Revolution 500–1000min⁻¹, feed rate 1000–2000 mm/min) 2. Stop the long type drill 0.5–1 mm short of the guide hole bottom.</p>	<p>4. Drill the deep hole</p>  <p>1. Start cutting at the recommended speed and feed with a non-peck (continuous feed) cycle.</p>
<p>5. Breaking through</p>  <p>1. When breaking through, the cutting edge can be damaged. 2. Lower the feed rate when penetrating.</p>	<p>6. Drill retraction</p>  <p>1. Finally clear the hole at a feed rate of 0.2–0.3 mm/rev. (Revolution of around 500–1000min⁻¹) 2. Retract the drill to the pilot hole depth starting point at a feed rate of 1000–2000 mm/min.</p>

MINI DVAS

OPERATIONAL GUIDANCE

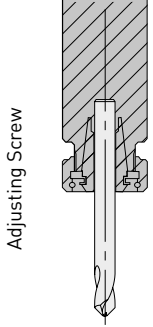
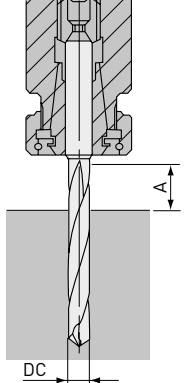
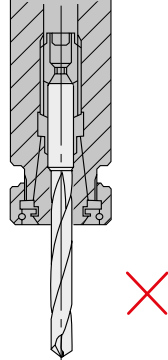
DRILL HOLDING	DRILL LENGTH	DRILL INSTALLATION	COOLANT PRESSURE									
 <p>Adjusting Screw</p>			<p>Adjust the coolant pressure according to the type and concentration of coolant.</p> <table border="1" data-bbox="1141 728 1420 884"> <thead> <tr> <th>Drill Dia. DC</th> <th>Water-soluble</th> <th>Water-insoluble</th> </tr> </thead> <tbody> <tr> <td>DC < 2 mm</td> <td>≥ 3 MPa</td> <td>≥ 7 MPa</td> </tr> <tr> <td>DC < 3 mm</td> <td>≥ 2 MPa</td> <td>≥ 5 MPa</td> </tr> </tbody> </table>	Drill Dia. DC	Water-soluble	Water-insoluble	DC < 2 mm	≥ 3 MPa	≥ 7 MPa	DC < 3 mm	≥ 2 MPa	≥ 5 MPa
Drill Dia. DC	Water-soluble	Water-insoluble										
DC < 2 mm	≥ 3 MPa	≥ 7 MPa										
DC < 3 mm	≥ 2 MPa	≥ 5 MPa										
<p>Thrust bearing type collet chuck holds the drill securely.</p>	<p>$A \geq DC \times 2$</p>	<p>Do not clamp on the flutes.</p>										

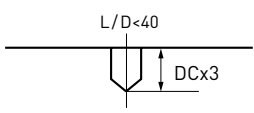
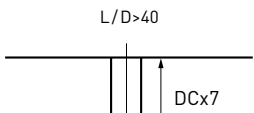
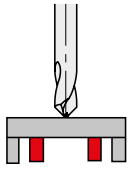
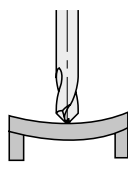
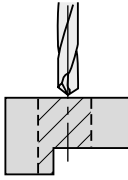
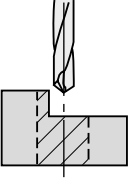
PILOT DRILL	COOLANT HANDLING	THIN WORKPIECE	INTERRUPTED CUTTING						
<p>For deep hole drilling, refer to the figure below.</p>  <p>$L/D < 40$ DCx3</p> <p>Use DVAS○○○○○○X02S040</p> <p>*L/D = 2 can be machined up to DCx3 when drilling pilot holes.</p>  <p>$L/D > 40$ DCx7</p> <p>Use DVAS○○○○○○X07S040</p>	<p>Small particles of swarf will jam in the oil hole of small diameter drills.</p> <p>Always use a fine mesh filter as a preventive measure.</p> <table border="1" data-bbox="486 1355 782 1523"> <thead> <tr> <th>Drill Dia. DC</th> <th>Fine Mesh Filter</th> </tr> </thead> <tbody> <tr> <td>DC < 2 mm</td> <td>≤ 10µm</td> </tr> <tr> <td>DC < 3 mm</td> <td>≤ 20µm</td> </tr> </tbody> </table>	Drill Dia. DC	Fine Mesh Filter	DC < 2 mm	≤ 10µm	DC < 3 mm	≤ 20µm	<p>Support the workpiece OK</p>  <p>If bending occurs NG*</p> 	<p>One process OK</p> <p>1. Lower the feed when drilling the interrupted part.</p>  <p>Requires prior machining</p> <p>1. Spot face with an end mill prior to drilling.</p> 
Drill Dia. DC	Fine Mesh Filter								
DC < 2 mm	≤ 10µm								
DC < 3 mm	≤ 20µm								

*NG – Displays chatter and vibration

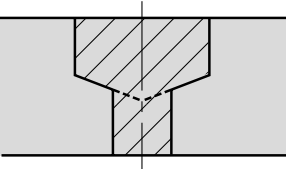
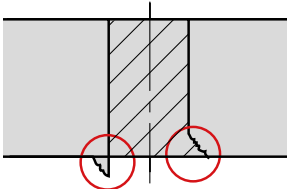
STEPPED HOLES	BURRING AND WORKPIECE CHIPPING
 <p>Divide the two processes.</p> <ol style="list-style-type: none"> 1. Drill the larger hole first. 2. A tool for machining both chamfer and spot face can be produced to order. 	 <ol style="list-style-type: none"> 1. Lower the feed rate by 50 % at the end of through cutting. 2. Change the point angle.

TIPS FOR DRILLING A DEEP HOLE EXCEEDING $L/D = 40$

WORKPIECE ROTATION METHOD: SMALL AND AUTOMATIC TYPE LATHES

(1) FACE COUNTERSINK (DLE DRILL IS RECOMMENDED)

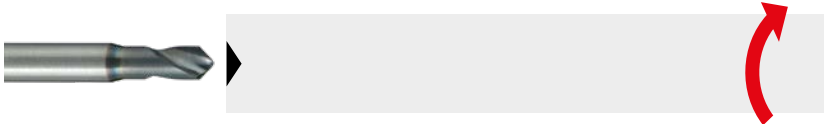

(2) DRILL THE GUIDE HOLE TO A DEPTH OF APPROX. 3D (DVAS DRILL IS RECOMMENDED)

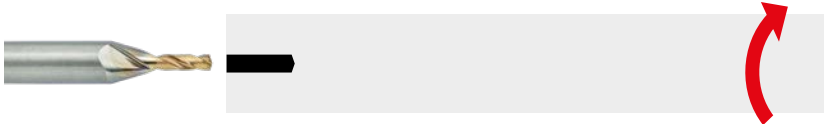

(3) DRILL THE DEEP HOLE USING DVAS0000X50S040



TOOL ROTATION METHOD: MACHINING CENTRES AND COMPOSITE TYPE MACHINES

(1) DRILL THE GUIDE HOLE TO A DEPTH OF APPROX. 3D (DVAS DRILL IS RECOMMENDED)

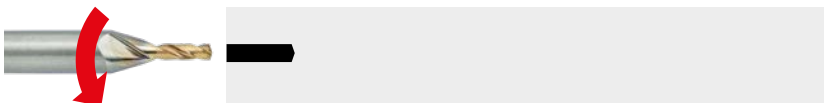

(2) DRILL THE GUIDE HOLE DEEPER TO A APPROX. 7D
IF MORE STABILITY IS REQUIRED, DRILL A GUIDE HOLE DEEPER THAN 7D



(3) DRILL THE DEEP HOLE USING DVAS0000X50S040

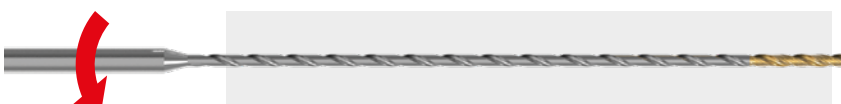

MINI DVAS

CUTTING EXAMPLE

COMPARISON OF DRILLING EFFICIENCY ON AN AUTOMATIC LATHE

Drilling efficiency is 10 times higher compared to gun drills.

It provides highly efficient and stable machining even when drilling alloy and stainless steels.

DRILLING OF 34CrMo4

GENERAL CUTTING CONDITIONS FOR GUN DRILLS

Cutting time 107.8 sec./hole

Tool	DC = \varnothing 2 mm, L/D = 50
Vc (m/min)	50
f (mm/rev)	0.007
ap (mm)	100
Cutting mode	Wet cutting, Oil, 15 MPa

DVAS

Cutting time 10.8 sec./hole

Tool	DC = \varnothing 2 mm, L/D = 50
Vc (m/min)	50
f (mm/rev)	0.07
ap (mm)	100
Cutting mode	Wet cutting, Oil, 15 MPa

DVAS DRILL APPLICATION



DRILLING OF X5CrNi18-10

GENERAL CUTTING CONDITIONS FOR GUN DRILLS

Cutting time 188.4 sec./hole

Tool	DC = \varnothing 2 mm, L/D = 50
Vc (m/min)	40
f (mm/rev)	0.005
ap (mm)	100
Cutting mode	Wet cutting, Oil, 15 MPa

DVAS

Cutting time 18.8 sec./hole

Tool	DC = \varnothing 2 mm, L/D = 50
Vc (m/min)	40
f (mm/rev)	0.05
ap (mm)	100
Cutting mode	Wet cutting, Oil, 15 MPa

DVAS DRILLING APPLICATION

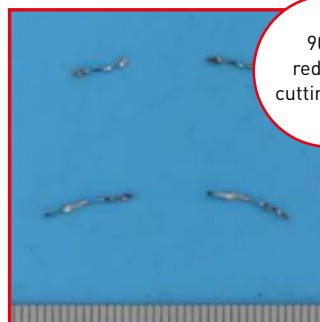

MINI DVAS

CUTTING EXAMPLE

EXAMPLE OF IMPROVED DRILLING EFFICIENCY ON AN AUTOMATIC LATHE

DVAS significantly reduces cycle times and ensures consistent drilling.

MINI DVAS

Material	C45E
Tool	DC = $\varnothing 2$ mm, L/D = 50
Vc (m/min)	70
f (mm/rev)	0.09 – 0.12
ap (mm)	117
Cutting mode	Wet cutting, Oil, 7 MPa

DRILLING PROCESS OF BOTH ENDS MACHINING

1. One side drilled with blind hole.

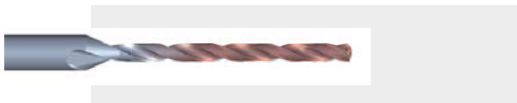

2. Workpiece is inverted for a through hole.

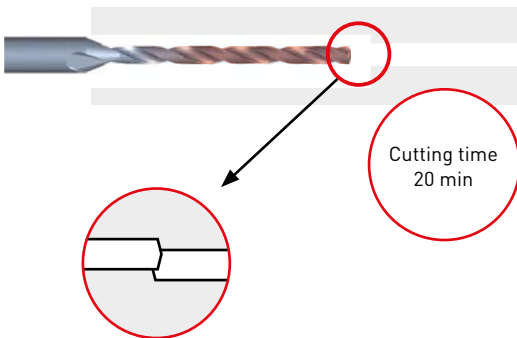

Hole mismatch is likely to occur.

DRILLING PROCESS WITH DVAS DRILL

1. Drilling a through hole from one side at a time.

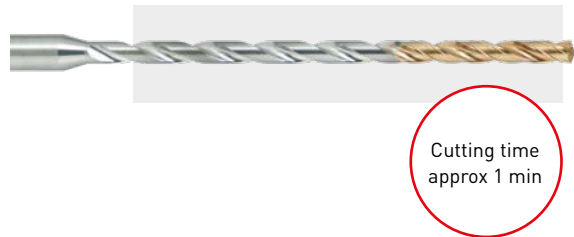

MINI DVAS

CUTTING PERFORMANCE

COMPARISON OF FRACTURE RESISTANCE WHEN DRILLING 42CrMo4

DVAS has excellent fracture resistance and double tool life compared to conventional products.

Material	42CrMo4
Tool	DC = Ø2 mm, L/D = 20
Vc (m/min)	50
f (mm/rev)	0.06
ap (mm)	40
Cutting mode	Wet cutting Water-soluble coolants, 2 MPa
Pilot drills	DC = Ø2 mm L/D = 2 Hole depth 4 mm

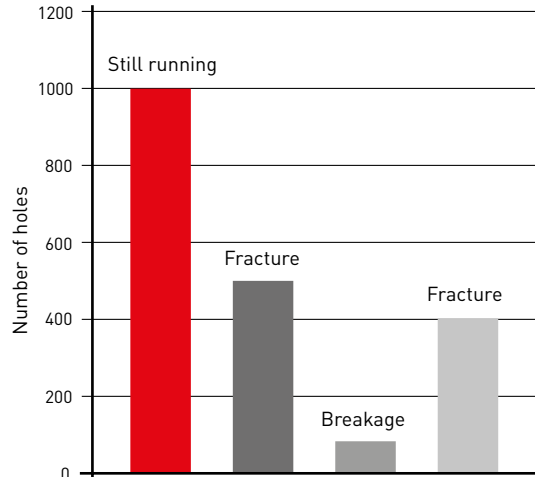
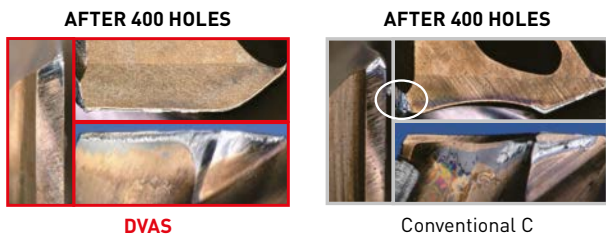

COMPARISON OF FRACTURE RESISTANCE DURING HIGH-EFFICIENCY CUTTING OF 42CrMo4

DVAS drill is very stable even under high-efficiency cutting conditions.

Material	42CrMo4
Tool	DC = Ø2 mm, L/D = 20
Vc (m/min)	70
f (mm/rev)	0.07
ap (mm)	40
Cutting mode	Wet cutting Water-soluble coolants, 2 MPa
Pilot drills	DC = Ø2 mm L/D = 2 Hole depth 4 mm/holes

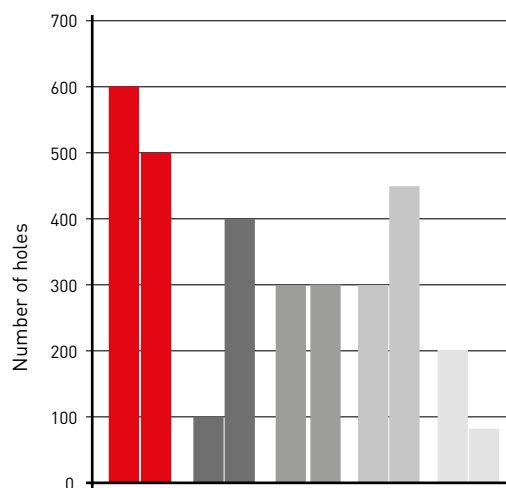
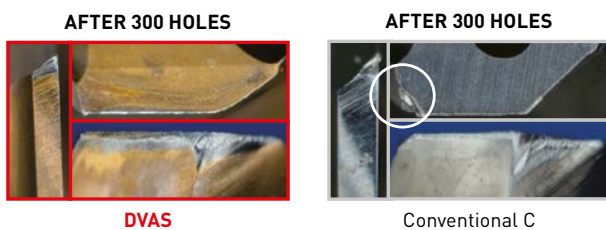

MINI DVAS

CUTTING PERFORMANCE

COMPARISON OF WELDING RESISTANCE AND CHIP DISPOSAL DURING HIGH-EFFICIENCY CUTTING OF X5CrNi189

Achieves excellent welding resistance and chip control when drilling stainless steels.

Material	X5CrNi18-10
Tool	Pilot drill DC = Ø2 mm, L/D = 2 Hole depth 4 mm
	Long drill DC = Ø2 mm, L/D = 20 Hole depth 40 mm
Vc (m/min)	50
f (mm/rev)	0.06
Cutting mode	Wet cutting Water-soluble coolants, 2 MPa

AFTER 1200 HOLES

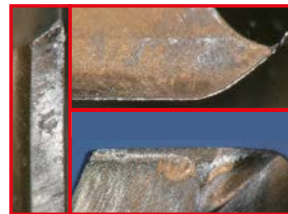

DVAS

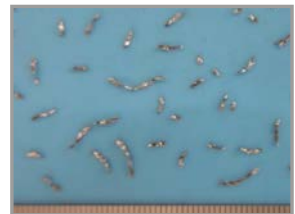
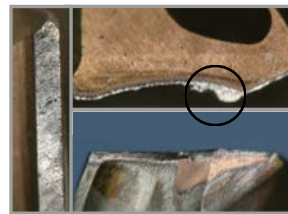

Conventional A

Some continuous chips



Conventional B

Continuous chips

COMPARISON OF BREAKAGE RESISTANCE WHEN DRILLING INCONEL®718

Increased coolant discharge rate achieves stable machining of heat-resistant alloys when compared to conventional products.

Material	Inconel®718
Tool	Pilot drill DC = Ø2 mm, L/D = 2 Hole depth 4 mm
	Long drill DC = Ø2 mm, L/D = 12 Hole depth 20 mm
Vc (m/min)	30
f (mm/rev)	0.03
ap (mm)	20
Cutting mode	Wet cutting Water-soluble Coolants, 2 MPa

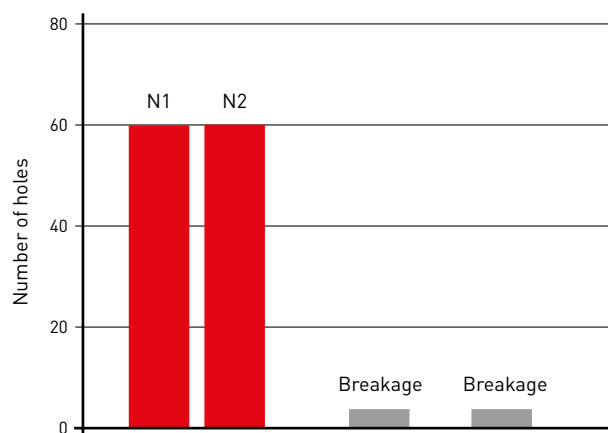

AFTER 60 HOLES

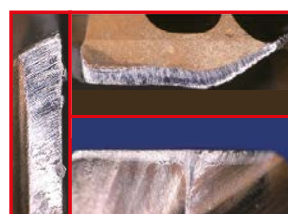

DVAS

MINI DVAS

CUTTING PERFORMANCE

HIGH-EFFICIENCY EXAMPLE OF CUTTING X5CrNi189 L/D = 50

Achieves excellent chip disposal and high efficiency when deep hole drilling in stainless steels.

Material	X5CrNi18-10
Tool	Pilot drill DC = \varnothing 2 mm, L/D = 2 Hole depth 4 mm
	Short drill DC = \varnothing 2 mm, L/D = 7 Hole depth 14 mm
	Long drill DC = \varnothing 2 mm, L/D = 50 Hole depth 100 mm
Vc (m/min)	60
f (mm/rev)	0.05
Cutting mode	Wet cutting Water-soluble coolants, 7 MPa

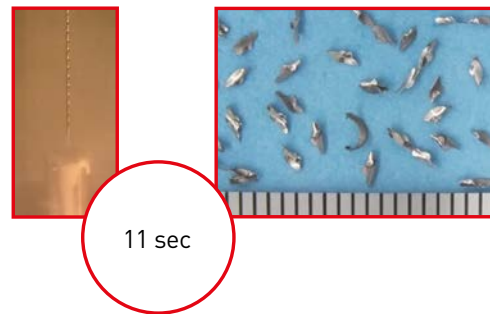

Material	X5CrNi18-10
Tool	Pilot drill DC = \varnothing 2 mm, L/D = 2 Hole depth 4 mm
	Short drill DC = \varnothing 2 mm, L/D = 7 Hole depth 14 mm
	Long drill DC = \varnothing 2 mm, L/D = 50 Hole depth 100 mm
Vc (m/min)	100
f (mm/rev)	0.08
Cutting mode	Wet cutting Water-soluble coolants, 7 MPa

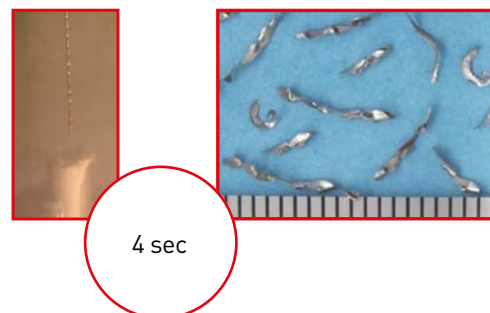

MINI DVAS

CUTTING PERFORMANCE

COMPARISON OF TRUE STRAIGHTNESS WHEN DRILLING 42CrMo4 L/D = 40

Hole wander is greatly reduced when compared to conventional products.

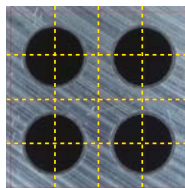
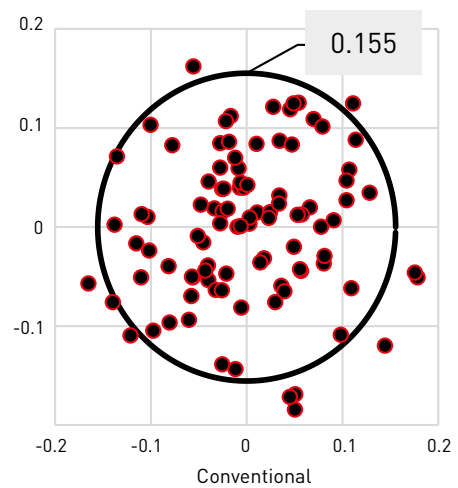
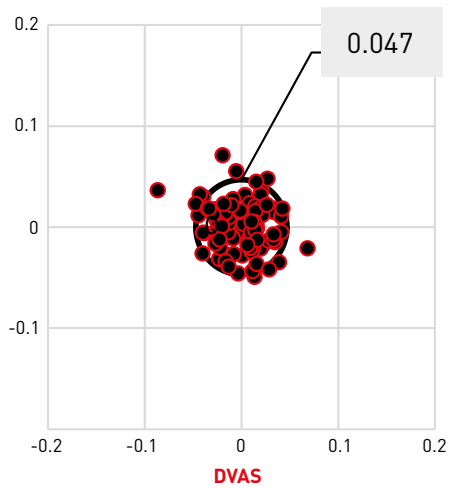

DVAS

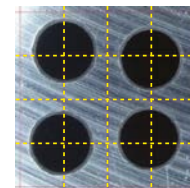

Conventional

Material	42CrMo4
Tool	Pilot drill DC = Ø2 mm, L/D = 2 Hole depth 4 mm
	Long drill DC = Ø2 mm, L/D = 40 Hole depth 80 mm
f [mm/rev]	0.07
Cutting mode	Wet cutting Water-soluble coolants, 7 MPa

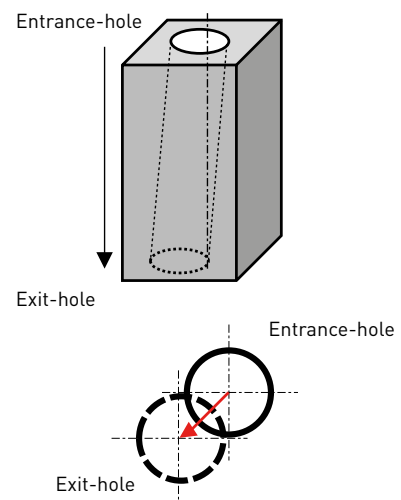

EUROPEAN SALES COMPANIES

GERMANY

MMC HARTMETALL GMBH
Comeniusstr. 2 . 40670 Meerbusch
Phone +49 2159 91890 . Fax +49 2159 918966
Email admin@mmchg.de

UK Office

MMC HARDMETAL UK LTD
1 Centurion Court, Centurion Way
Tamworth, B77 5PN
Phone +44 1827 312312
Email enquiries@mitsubishicarbide.co.uk

UK Deliveries / Returns

Unit 4 B5K Business Park, Quartz Close
Tamworth, B77 4GR

SPAIN

MITSUBISHI MATERIALS ESPAÑA, S.A.
Calle Emperador 2 . 46136 Museros/Valencia
Phone +34 96 1441711
Email comercial@mmevalencia.es

FRANCE

MMC METAL FRANCE S.A.R.L.
6, Rue Jacques Monod . 91400 Orsay
Phone +33 1 69 35 53 53 . Fax +33 1 69 35 53 50
Email mmfsales@mmc-metal-france.fr

POLAND

MMC HARDMETAL POLAND SP. Z O.O
Al. Armii Krajowej 61 . 50-541 Wrocław
Phone +48 71335 1620 . Fax +48 71335 1621
Email sales@mitsubishicarbide.com.pl

ITALY

MMC ITALIA S.R.L.
Viale Certosa 144 . 20156 Milano
Phone +39 0293 77031 . Fax +39 0293 589093
Email info@mmc-italia.it

TURKEY

MMC HARTMETALL GMBH ALMANYA - İZMİR MERKEZ ŞUBESİ
Adalet Mahallesi Anadolu Caddesi No: 41-1 . 15001 35530 Bayraklı / İzmir
Phone +90 232 5015000 . Fax +90 232 5015007
Email info@mmchg.com.tr

www.mmc-carbide.com

DISTRIBUTED BY:

□

□

└

└

B267E 

Published by: MMC Hartmetall GmbH – A Sales Company of  MITSUBISHI MATERIALS | 2025.04